

Bath

Information Pack



Index

	Page
Introduction	2
Solutions to bathing problems	3
Bath boards	5
Bath seats	7
Rails	9
Bath lifts	10
Bath hoists	11
Replacement baths and Showers	12
Accessories	14
Consumer Advice	16
Contacts	19
Consumer Agencies	21
Retailers and Services	24

This booklet is only for general guidance. The safe use and/or fitting of any equipment that is mentioned in this booklet is the user's responsibility. Neither ESDA nor the Social Services Department can accept any responsibility for misinterpretation or misuse of this information or devices acquired by the user. ESDA and ESCC reserve the right to revise this booklet as necessary from time to time without prior notice.

Bathing

Getting in and out of the bath requires agility, strength, good grip and co-ordination. We are all individuals and our abilities vary because of differences in age, size, shape, disabilities, and illnesses. A personal care task like bathing can, for some, become very difficult, demand a great deal of effort, or even become dangerous.

Introduction

This booklet was developed by the East Sussex Disability Association (ESDA) in co-operation with the East Sussex County Council (ESCC) Social Services Department. The booklet is intended to help you, or your carer, think of ways to overcome your bathing problems. It gives you information about the various types of bathing equipment available. After reading this booklet you may have discovered ways of solving your bathing problems on your own. However, if you feel you need more detailed information and advice before purchasing equipment, you may want to make an appointment with the Occupational Therapist at the Disabled Living Centre at ESDA. (See enclosed information on page 19). If, as a result of reading this pack, you wish to purchase a piece of equipment, there is a list of Suppliers (see page 24) and a Consumer Advice section (see page 16). If you are *permanently* and *substantially* disabled, you may be eligible for a home assessment by a Social Services Occupational Therapist (see page 23 for contact details).

Possible solutions to bathing problems

A successful solution to your bathing problem depends on matching the suggestions given below to your ability and the bathing facility. Suggestions are:

1. Choosing not to bath

You can choose not to bath but to strip wash near a basin. You may sit on a chair, a perching stool (see page 15), or a bath board (see page 6).

If you sit on a bath board you can either strip wash or use an over bath shower attachment.

If you have problems with washing yourself, there are various pieces of equipment such as long handled sponges and tap turners, which you might find useful (see page 14).

2. Finding ways to get into and out of your bath

The two main difficulties people have with using the bath are stepping over the side of the bath and getting in and out of the water. Whichever solution you choose it is recommended that you use a non-slip bath mat. To help you can:

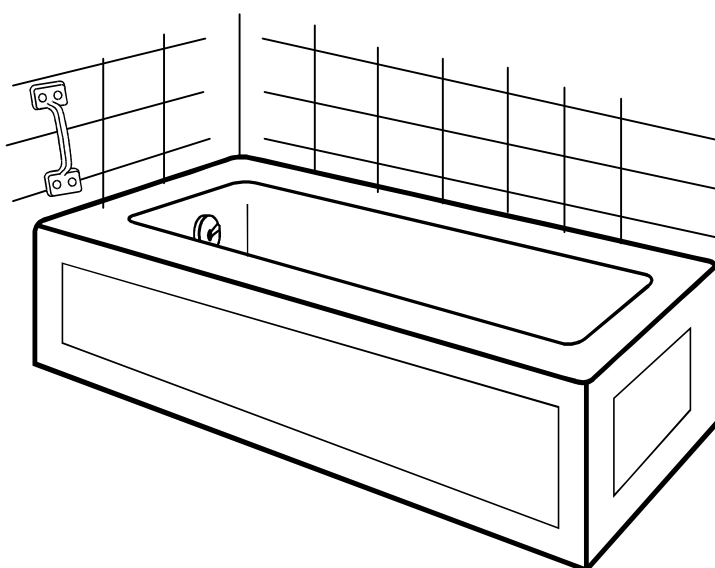

-
- a) Use a grab rail to assist you to step safely over the side of the bath.
 - b) Sit on a bath board and safely lift your legs over the side of the bath. (See Instructions on page 6).
 - c) Use a grab rail to lower yourself down to the bottom of the bath or half way to a bath seat.
 - d) Lower yourself down on to a bath seat from the bath board, and when getting out, raise yourself up from the bath seat back on to the bath board. (See instructions on page 8).
 - e) Use a bath lift. (See page 10).
 - f) Use a bath hoist. (See page 11).

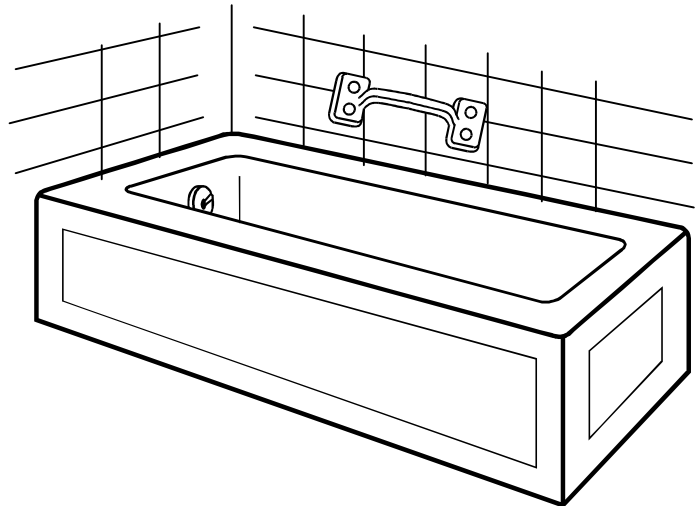

3. Replacing the bath

You can replace your bath with a special bath or shower. For information on special baths see page 12. For information on replacing the bath with a shower unit see page 12.

4. Other Options

If you feel that your bathing needs would be better met by paying a personal carer from an agency or attending a Day Centre then contact your local Social Services

Independent Living Team (see page 22 for contact details).

Bath Boards

Description:

A bath board fits across the bath to help you to transfer into the bath. You can either stay on it to strip wash, or use it together with a bath seat. The purpose of the bath board is to assist you to transfer safely into the bath without having to firstly step in or stand. It does not lower you into the water.

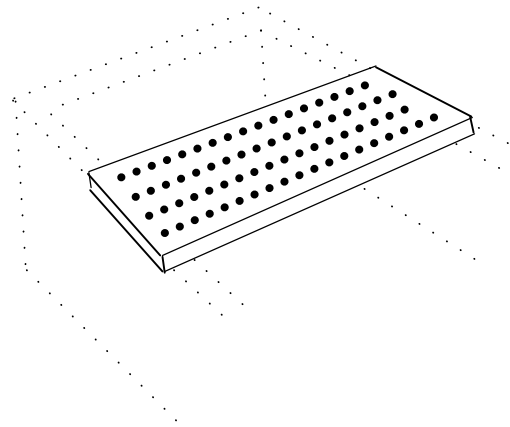

Types available:

Bath boards are available in various lengths, widths, types and materials. Slatted or perforated types are available for use with an over bath shower.

Approximate price:

£15 - £40.

Fitting Instructions:

All types of bath boards have some means of adjustment underneath to enable the board to be fitted securely to the bath. The fitting must be checked periodically and adjusted if necessary. The board must not be wider than the bath so that it cannot tip when you are transferring on and off it. There must be an adequate ledge on the wall side of the bath for the board to fix safely. If you have an acrylic or a sculptured bath, fitting a bath board may not be possible. The board should come with fitting and cleaning instructions and a user weight limit.



How to use the bath board

Getting in to the bath:

1. Sit on the board, shift your bottom towards the centre.
2. Swivel your bottom round as you lift your legs over the bath edge.
3. You should end up in this position. Your weight should be as central on the board as possible.

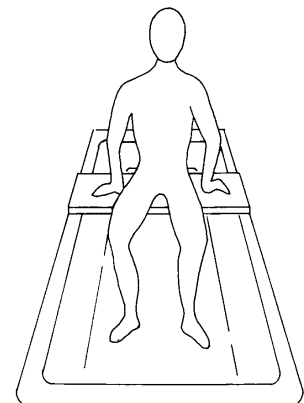
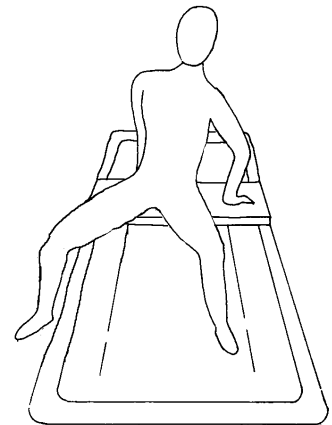
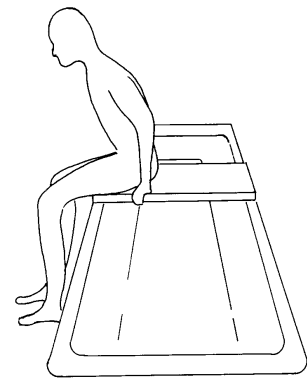

When getting out of the bath do the reverse.



Safety note

- Always use a good quality bath mat and replace it when it begins to show signs of perishing.
- Have everything within reach before getting into the bath.
- Fill bath before getting in.

Always test the water temperature before getting into the bath.

Bath seats

Description:

A bath seat can be used with just a rail and a mat but more often it is used together with a bath board to assist you getting in and out of the bath. Once you are sitting on the bath seat stay there to wash and do not try to go further down into the bath.

Types available:

Bath seats are available in heights from 6" to 11". They can either be free standing on suction pads in the bath, be wedged inside the bath or be suspended from the top of the sides of the bath.

NB. Wedge type not to be used on acrylic baths

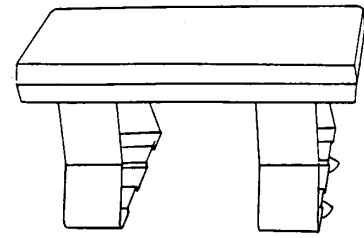

Free standing type

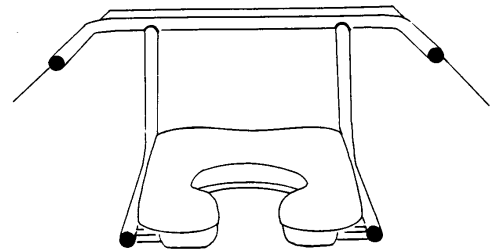

Suspended type.

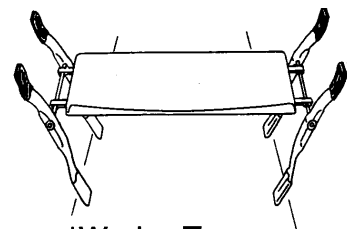

*Wedge Type
not to be used in acrylic baths

Approximate price:

£20 - £50.

Fitting Instructions:

Seats should come with fitting and cleaning instructions and an indication of a weight limit. It is very important for bath seats to be fitted correctly and securely. The fitting must be checked periodically and adjusted if necessary.



How to use the bath seat

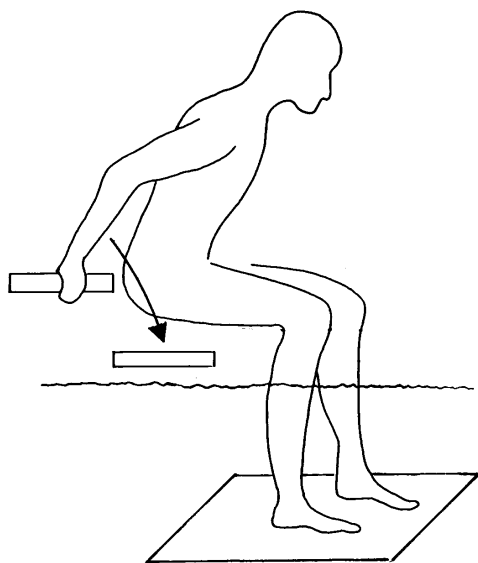

Getting down

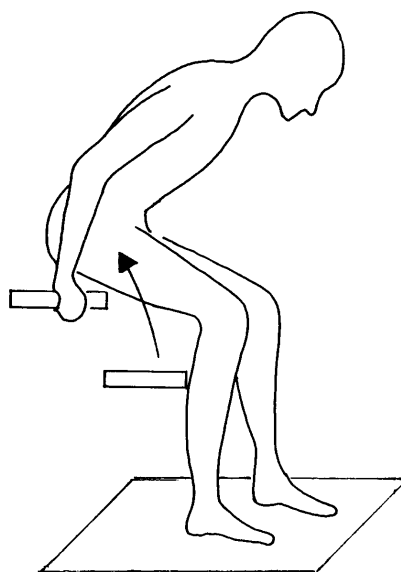

Getting up

Hold onto the board, place feet flat the bottom of the bath, knees well bent, supporting your weight on your hands move either forwards down on to seat or backwards to sit up on the board



Safety note

- Ensure that you have the appropriate seat for your bath.
- Always use a good quality bath mat and replace it when it begins to show signs of perishing.
- Empty bath before getting out.

Transferring from board to seat (or seat to board) requires strength in both arms and a good sense of balance.

Rails

i Description:

A rail provides you with stable support if you are in danger of losing your balance.

Types available:

Rails can be straight or angled and fixed to the walls, floor or bath. Sometimes they can be floor to ceiling poles. It is recommended that rails used for bathrooms are plastic or plastic coated, and that metal screws are covered with plastic screw caps. If bare metal rails are used they should be earthed.

£ Approximate price:

£6 upwards plus fitting.

🔧 Fitting Instructions:

Rails must be professionally installed.

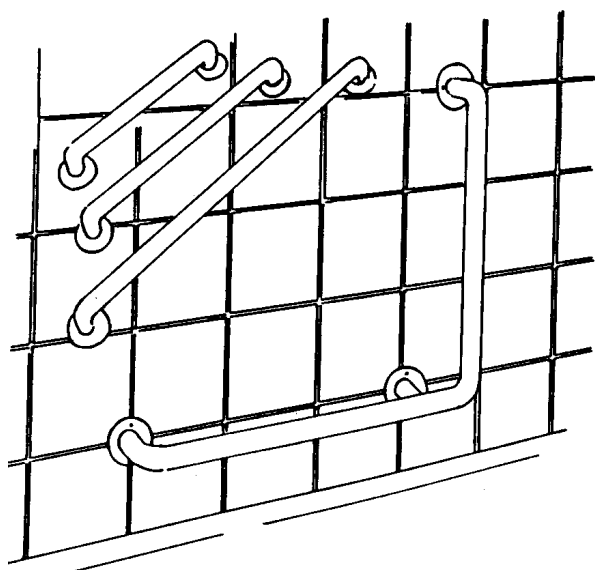

Straight Rails /
Angled Rails

Bath lifts

i Description:

There are various types of bath lift that can either remain permanently in the bath or be removed as necessary. Lifts are usually powered by a battery or by an air compressor but some are mechanically operated. They do not need permanent fitting but some require access to a power supply outside the bathroom.

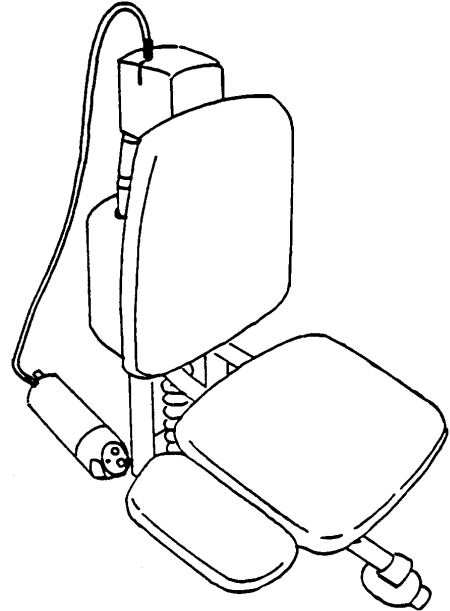

Bath lifts are heavier to lift than bath boards and seats. This is important when other members of the family wish to use the bath without the bath lift. Bath lifts greatly reduce the physical effort of getting in and out of the bath. However, you will still need to get on and off the lift by sitting on it and raising your legs over the edge of the bath. Bath lifts allow you to get further down into the water than a bath seat. Some types may have trailing leads on the floor, which can be a hazard if you have mobility problems or poor eyesight. The weight limit varies from product to product.

Several bath lifts can be seen and tried at the Disabled Living Centre at ESDA.

f Approximate price:

Bath lifts cost considerably more than boards and seats. Prices start from about £360. It is important to ensure that the bath lift is suitable for your bath particularly if you have an acrylic bath.

Bath hoists



Description:

Bath hoists require space and must be professionally installed. They consist of a column attached either to the floor or to the bath.

They have a seat that can be moved up and down and in and out of the bath. They can be operated by means of a winding handle, mains electricity or battery power.

It is possible to use a mobile hoist or ceiling fixed hoist for bathing. A mobile hoist would be used if you require maximum assistance and also need a hoist in other situations apart from bathing. If you are very severely disabled, other lifting equipment and ceiling fixed hoists may be available through assessment by the Social Services Occupational Therapist.

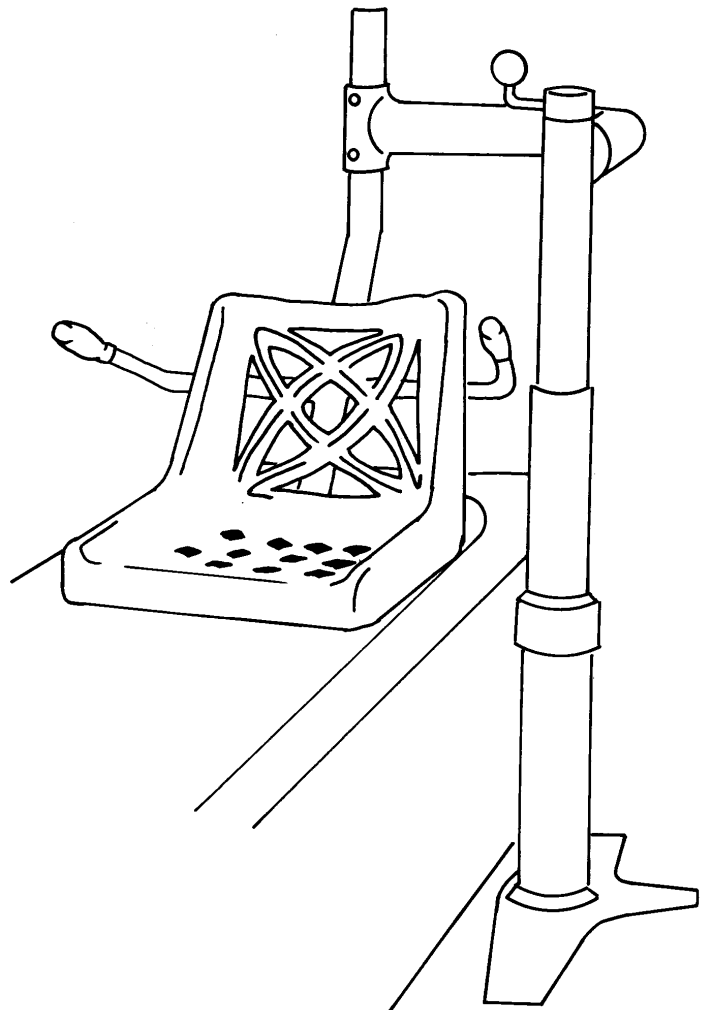

Replacement baths & Showers

i Description:

Replacement special baths can have the following special features: a side door entry, walk-in facility or built-in or swivel seats, and can be adjustable in height or position. They tend to be quite large, heavy and expensive.

When using a bath with a side entry you have to totally fill and empty the bath whilst sitting in it. Closing the door can require a fair amount of strength and agility.

Replacement of the bath with a shower unit - If you decide to replace the bath with a shower, avoid standard shower cubicles. These often have a large step, little room to sit down and rails cannot be installed at a later date should your needs change.

Showers can be built to have easy access or total level access. It is advisable for safety reasons to choose a temperature-controlled shower with easy to use controls. There are various kinds of shower stools and chairs, rails, screens, curtains, body dryers and other accessories available.

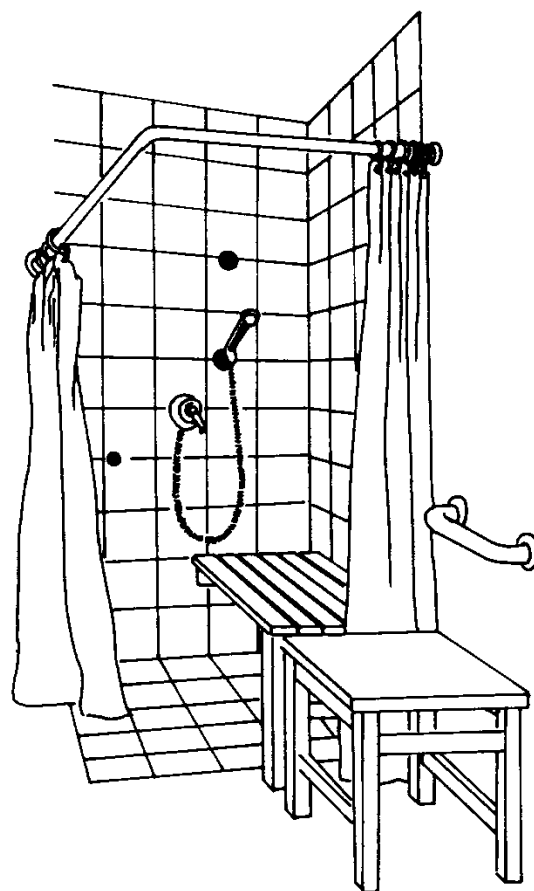
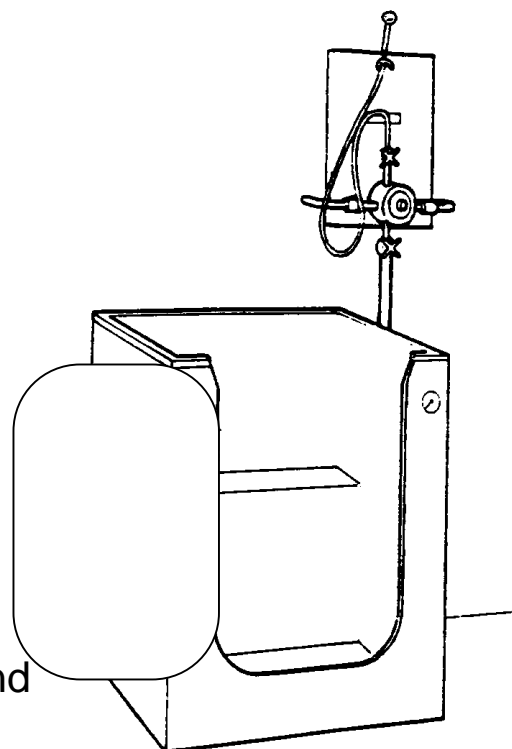

Where the only solution is to adapt the home, for example by providing a shower, there may be grants available. However, these are only available to people who are permanently and substantially disabled and have been assessed by the Social Services Occupational Therapist. Such grants are available but are subject to financial assessment. A written approval of any grant is required before ordering works as no retrospective payments are given. The Occupational Therapist at the Disabled Living Centre can advise you further.

If you are planning to carry out adaptations privately or via a grant, free advice is available to older and disabled people from your local Care & Repair Home Improvement Agency. They can also provide technical services for which a fee may be charged. Contact details for Home Improvement Agencies are on page 22.

Equipment and adaptations can be expensive, especially if you are having to pay all or most of the cost. If you find it difficult to raise the money do ask the supplier if they have a finance or hire purchase scheme. Your bank or building society may also be able to help.

Accessories

i Description:

Bidet - a portable bidet that can be placed on the WC pan to enable you to attend to your personal hygiene.

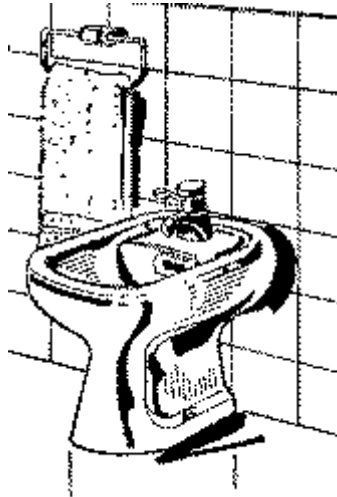

Tap Turners and lever taps

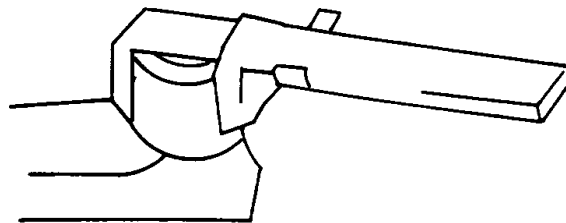

Long handled sponges, brushes

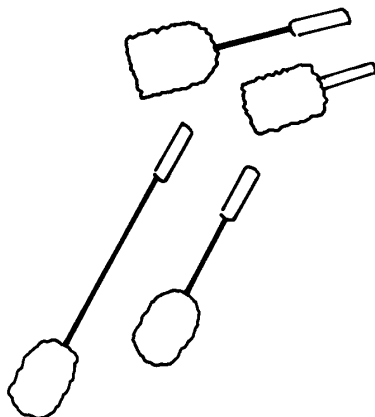

Perching stool to sit on at the basin (not suitable for baths).

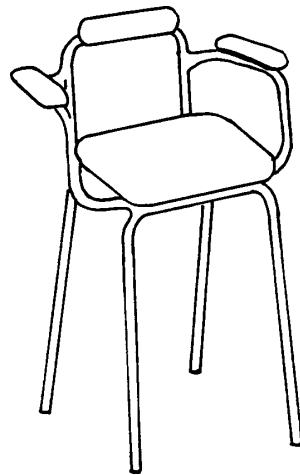

Bath Mat

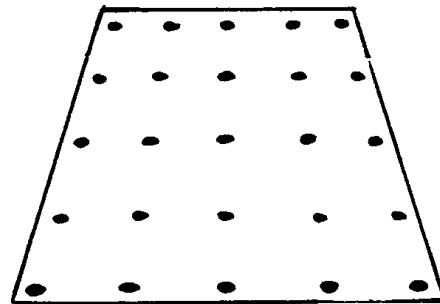

Bath Cushion

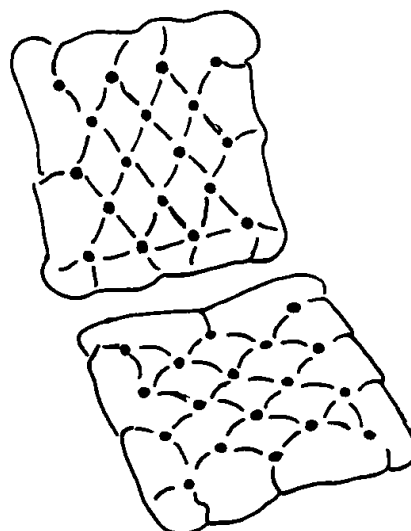

These and similar items can be seen at the Disabled Living Centre.

Consumer advice

If you decide to buy a piece of equipment, the following advice may be of use to you.

Pre-shopping tips and advice:

- The Office of Fair Trading produce a booklet called 'A Buyer's Guide' that contains comprehensive information on your rights as a consumer (Telephone 0207 211 8000).
- You can ask the retailer for customer references of people who have recently purchased similar equipment from them.
- Check whether the retailer offers a trial period for you to try out a particular piece of equipment. This may be particularly important if you are spending a substantial amount of money. Get this offer confirmed in writing before you take it up.
- If you buy second hand goods from a retailer the same rules apply as to new goods. However, you must consider the age of the goods; the older they are, the more wear and tear you must expect. Remember, existing guarantees do not transfer upon the resale of goods.
- Think about your purchase, its suitability to your needs and its price. Make sure you are getting exactly what you want and need.
- Do not rush into a purchase; consult as many suppliers as possible before making your decision.
- Find out if you are eligible for VAT relief (see page 18).

Safety / Faults / Dissatisfaction

Safety Aspects, Faults and Dissatisfaction with Goods

If you have a query or a problem regarding the safety of equipment, your local County Council Trading Standards Department is the appropriate body to contact.

If safety is not an issue, general complaints fall under the category of Civil Law. The Trading Standards Department may be able to advise here. In general, you should first approach the retailer, as soon as possible after purchase, for a refund or exchange. It is advisable to keep copies of all correspondence and make notes of all telephone conversations. If you do not achieve a satisfactory result, your local Citizen's Advice Bureau will be able to offer help and advice. Alternatively you can contact the Information Officer at the East Sussex Disability Association.

If you are not satisfied with the goods you have purchased because they are faulty, you may use your statutory rights to seek redress from the retailer. The law says that the goods

- must be of satisfactory quality, that is, goods should do their job properly. They should normally be free from minor defects, have a reasonable appearance and finish and be safe and durable. (Remember cheaper goods cannot be expected to be as good as something that is more expensive).
- must be fit for their purpose, including any particular purpose mentioned by you to the seller. For example, you may state that you require a bath lift that is capable of lifting a weight of 20 stones.
- must be as described on the package or display sign by the seller.

If your piece of equipment does not comply with these three categories you will be entitled to get something done about it. However, suppliers are under no obligation to give an exchange or refund if you have simply changed your mind, were told in advance about any existing fault, or damaged the equipment yourself.

Value Added Tax

Certain equipment for disabled people may qualify for tax relief under the VAT Act 1994. If you are 'Chronically Sick or Disabled' (you will be asked to define your illness/disability), you may be entitled to zero rated tax when buying equipment for your domestic or personal use. However, it is vital that a declaration to this effect is signed at the point of sale, as VAT will not be refunded at a later date. For further information and a leaflet please contact VAT Office, 315 Portland Road, Hove BN3 5SZ tel: 01273 430011.

Contacts

1. Disabled Living Centre

What is a Disabled Living Centre?

We are a resource centre for disabled people, their carers, professionals and interested organisations. We offer advice and a wide range of information regarding disability equipment.

What can we offer you?

We have a permanent display of equipment to assist with independence for disabled people, giving you the chance to see and try out a wide range of products to suit your individual needs. A qualified Occupational Therapist is available to give free, confidential and unbiased expert advice and information about equipment, costs and retail outlets. We offer practical solutions to difficulties concerning all aspects of daily living. Special demonstration and training sessions for groups can also be arranged.

Where can you get these products?

Some products are available on loan from your Social Services or from the Health Service. You will usually need a visit from either the Disability Team or hospital Occupational Therapist who will help you decide what you are eligible for. Alternatively, we can offer guidance regarding what is available from Health or Social Services and if there is anywhere else you can loan or hire products. Of course you may want to think about buying your own and need information regarding specialist shops, mail order catalogues and local chemists. We offer information about who is selling what in your area and how much you should expect to pay.

Who can use this service?

Anyone! This free service is not only available to disabled people. We also welcome senior citizens, their friends and families and anyone who needs a bit of help to stay active and care for themselves.

How can you use this service?

We can provide a lot of information over the telephone but if you wish to visit us to see and try out the equipment please make an appointment with the Occupational Therapist.

Buying - points to consider...

Special equipment can be expensive. You need to be sure that it is the right product for you. If you are at all unsure about whether the product is really suitable, contact the DLC for advice before you buy.

Advice and assessment available at the DLC

The following information is useful when visiting the Disabled Living Centre or shops:

1. What is your bath made of?
2. Has it any special features such as rails or is it sculptured or shallow?
3. What size is it?
 Inside Width..... Length..... Depth.....
 Outside Width..... Length..... Depth.....
4. Do you have a shower attached to taps/over bath shower?
5. Can you manage the taps?
6. How easy is it to get to your bathroom?
7. What size is your bathroom? Make a sketch if you think it would help.
8. What kind of bathing equipment have you used previously?
9. Do you have any equipment at home?
10. Do you have anyone to help you bath?

1. East Sussex Disability Association

Disabled Living Centre
1 Faraday Close
Hampden Park
Eastbourne
BN22 9BH

Tel: 01323 514515

Fax: 01323 514501

Textphone: 01323 514502

Email: info@esda.org.uk

Website: www.esda.org.uk

ESDA: Opening hours
Mon - Fri 9.00 am to 5.00 p.m.

**Visits to Disabled Living Centre
by appointment only**

2. Consumer Agencies

Trading Standards
Department for
Consumer Advice
1 Upperton Gardens
Eastbourne BN21 ISW
Tel: 01323 647381

The Office of Fair Trading
PO Box 2
Central Way
Feltham
Middlesex TW14 0TG

3. Citizen's Advice Bureau (C.A.B.)

There are several Citizen's Advice Bureau offices in East Sussex. Please look in the telephone book for the number of your local one. The main offices are listed below:

Lewes

3 North Street, Lewes
Tel: 01273 473082

Hastings & Rother

24 Cornwallis Tce,
Hastings
Tel: 01424 430400

Eastbourne

66 Grove Road, Eastbourne
Tel: 01323 417177

Bexhill & District

38 Sackville Road, Bexhill
Tel: 01424 215055

4. Home Improvement Agencies

North Wealden

Anchor Staying Put
39 New Town
Uckfield TN22 5DE
Tel: 01825 761018

South Wealden

Anchor Staying Put
78 A High Street
Hailsham BN27 1 AU
Tel: 01323 441013

Lewes

Anchor Staying Put
16 High Street
Lewes BN7 2LN
Tel: 01273 478001

Eastbourne

Care & Repair
2nd Floor
68 Grove Road
Eastbourne BN21 IDF
Tel: 01323 415355

Rother

Moat Care & Repair
Cemetery Lodge
250 Turkey Road
Bexhill TN39 5HT
Tel: 01424 216077

Hastings

Moat Care & Repair
Ground Floor
7 Havelock Road
Hastings TN34 1 BP
Tel: 01424 721992

5. Social Services Independent Living Teams

Eastbourne Area

Esher House
48 St Leonard's Road
Eastbourne BN21 3UF
Tel: 01323 532237

Lewes Area

Downlands
Roundhay Avenue
Peacehaven BN10 8TG
Tel: 01273 585881

South Wealden

Warwick House
Warwick Road
Seaford BN25 1RG
Tel: 01323 897575

North Wealden

1-6 Horsted Square
Uckfield
East Sussex TN22 1QL
Tel: 01825 766888

Hastings & Rother

Ocean House
87 – 89 London Road
St. Leonards on Sea
East Sussex TN37 6AR
Tel: 01424 448500

6. Social Services Disability Teams

(Occupational Therapists)

Eastbourne

10 Pembury Road
Langney
Eastbourne
East Sussex BN23 7HQ
Tel: 01323 768444
Fax: 01323 768450

Hastings and Rother

Ocean House
87 – 89 London Road
St. Leonards on Sea
East Sussex TN37 6AR
Tel: 01424 448500
Fax: 01424 448568

Wealden

1 & 6 Horsted Square
Bellbrook Estate
Uckfield
East Sussex TN22 1QL
Tel: 01825 760399
Fax: 01825 761179

Lewes

Downlands
Roundhay Avenue
Peacehaven
East Sussex BN10 8TG
Tel: 01273 582244
Fax: 01273 588811

Retailers & Services

The ESDA's Disabled Living Centre (Tel: 01323 514515) has compiled a list of suppliers for specialist equipment. It is emphasised that the choice of suppliers is entirely a matter for you, and need not to be from this list. This list is not a recommendation or a reference list. ESDA cannot be held liable for any claims that may arise as a result of goods purchased by you.

Contact	Service
Southern Mobility 2a Cavendish Avenue Eastbourne Tel: 01323 641798	Bath lifts, bath hoists and other relevant equipment. Will do home visits.
Procters 6 Station Parade Eastbourne Tel: 01323 417508	Bathing and personal care equipment, shower and shower loo. Also have hire service for some equipment and they sell second hand equipment. Will do home visits.
ESL (Eastbourne Showers) Unit 23 Potts Marsh Ind. Est. Eastbourne Rd, Westham Pevensey Tel: 01323 765875	Manufacturers of shower trays and cubicles for elderly and disabled people. Also suppliers of bathing and personal care equipment.
Southern County Care 7 Hailsham Rd Heathfield Tel: 01435 862952	Company providing a variety of bathing equipment.

Contact	Service
<p>Mobility Plus 1 The Centre High Street Polegate Tel: 01323 484060</p> <p>61 Boundary Road Hove BN3 5TD Tel: 01273 424224</p>	<p>Small household, bathing, walking equipment, wheelchairs, chairs etc.</p> <p>Also do building works such as bathroom adaptations etc.</p>
<p>Chapels Pharmacy & Chemist 1 Croft Road Crowborough Tel: 01892 562012</p>	<p>Chemist who has a small number of items in stock. Will order on request.</p>
<p>A J Mobility (Engineering) Unit 17 North Crescent Diplocks Way, Hailsham Tel: 01323 847250</p>	<p>Various daily living equipment, also some for bathing and showering.</p>
<p>Blooms Chemists Bohemia Road Hastings Tel: 01424 421072</p>	<p>Small number of bathing equipment in stock. Will get equipment that they do not have in stock.</p>
<p>Bexhill Mobility & Health Care Centre 37 St. Leonard's Road Bexhill on Sea Tel: 01424 219191</p>	<p>Display of bathing and personal care equipment. Can order items if not in stock.</p>
<p>East Sussex Mobility 7 Terminus Road Bexhill on Sea Tel: 01424 730488</p>	<p>Small amount of bathing equipment.</p>

Contact	Service
Little Common Pharmacy 77 Cooden Sea Road Bexhill on Sea	Equipment available specified in Home Health Catalogue. This catalogue is available from pharmacy.
Bounds Chemists 44 Broad Street Seaford Tel: 01323 892660	Equipment available specified in Home Health Catalogue. This catalogue is available from pharmacy.
Mobility Plus 61 Boundary Road Hove Tel: 01273 424224	Main shop in Polegate. Retailers of bathing and personal care equipment.
Lloyds Chemist 105 Church Road Hove Tel: 01273 732216	Upstairs showroom with bathing and other personal care equipment. Free delivery.
Access Mobility 139 Royal George Road Burgess Hill Tel: 01444 242228	Bathing and showering equipment. Bathroom adaptation work carried out.
Orange Badge Mobility Services Unit 15a The Granary Northeast Farm Whiteways Lane, Rodmell Tel 01273 473838	No actual showroom but a catalogue available. Will do home visits.

Contact	Service
Bakers Chemist 44 High Street Lewes Tel: 01273 472558	Some small aids available from a catalogue.
Care Centres Ltd 75 Rowlands Road Worthing West Sussex BN11 3JN Tel: 01903 821515	Electric and manual wheelchairs. Surgical appliances and disabled equipment
Age Concern East Sussex 54 Cliffe High Street Lewes Tel: 01273 476704 Local branches: Hastings 01424 426162 Battle 01424 775721 Hailsham 01323 844398 C'borough 01892 663728 Eastbourne 01323 638474	Can give details of the branches that sell small items. They can help in processing special orders for customers on a sale and return basis.
Mail order Catalogues	
Chester Care Ways & Means Functional Solutions Spencer Keep Able Ability Independence	Tel: 01623 757955 Tel: 0115 945 2345 Tel: 01254 619000 Tel: 01535 272957 Tel: 08705 202122 Tel: 0116 270 0515 Tel: 01353 667722

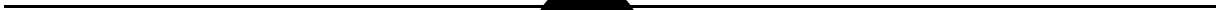



Content: Tarja Taylor (ESDA),
Julian Fowler and Lorna Couldrick (Social Services)

Design: Kate Griffiths, Communications Unit
Social Services

Copies: Social Services Information Line on (0845) 6010664
www.eastsussexcc.gov.uk/soc

or

East Sussex Disability Association on (01323) 514500
www.esda.org.uk

Issued: November 2000